

LMS1487

5V Low Power RS-485 / RS-422 Differential Bus Transceiver

General Description

The LMS1487 is a low power differential bus/line transceiver designed for high speed bidirectional data communication on multipoint bus transmission lines. It is designed for balanced transmission lines. It meets ANSI Standards TIA/EIA RS422-B, TIA/EIA RS485-A and ITU recommendation and V.11 and X.27. The LMS1487 combines a TRI-STATE™ differential line driver and differential input receiver, both of which operate from a single 5.0V power supply. The driver and receiver have an active high and active low, respectively, that can be externally connected to function as a direction control. The driver and receiver differential inputs are internally connected to form differential input/output (I/O) bus ports that are designed to offer minimum loading to bus whenever the driver is disabled or when $V_{CC} = 0V$. These ports feature wide positive and negative common mode voltage ranges, making the device suitable for multipoint applications in noisy environments. The LMS1487 is available in a 8-Pin SOIC and 8-pin DIP packages. It is a drop-in socket replacement to Maxim's MAX1487

Features

- Meet ANSI standard RS-485-A and RS-422-B
- Data rate 2.5 Mbps
- Single supply voltage operation, 5V
- Wide input and output voltage range
- Thermal shutdown protection
- Short circuit protection
- Low quiescent current 320µA
- Allows up to 128 transceivers on the bus
- Open circuit fail-safe for receiver
- Extended operating temperature range $-40^{\circ}C$ to $85^{\circ}C$
- Drop-in replacement to MAX1487
- Available in 8-pin SOIC and 8-pin DIP package

Applications

- Low power RS-485 systems
- Network hubs, bridges, and routers
- Point of sales equipment (ATM, barcode scanners,...)
- Local area networks (LAN)
- Integrated service digital network (ISDN)
- Industrial programmable logic controllers
- High speed parallel and serial applications
- Multipoint applications with noisy environment

Typical Application

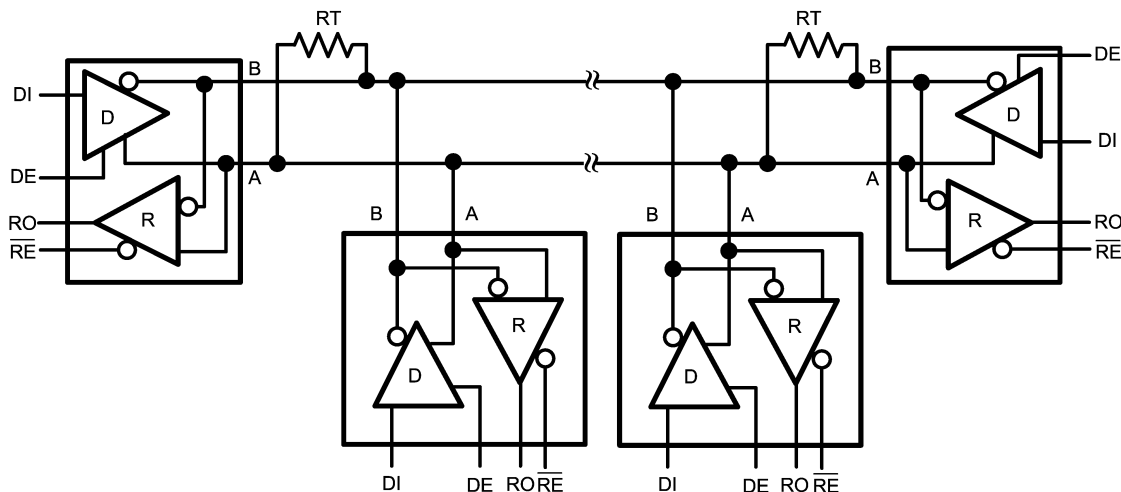

A Typical multipoint application is shown in the above figure. Terminating resistors, RT , are typically required but only located at the two ends of the cable. Pull up and pull down resistors maybe required at the end of the bus to provide fail-safe biasing. The biasing resistors provide a bias to the cable when all drivers are in TRI-STATE, See National Application Note, AN-847 for further information.

20053001

Connection Diagram

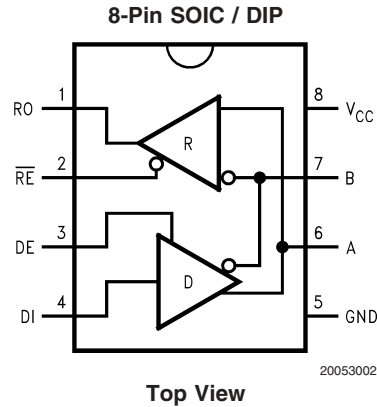

Truth Table

DRIVER SECTION				
\overline{RE}	DE	DI	A	B
X	H	H	H	L
X	H	L	L	H
X	L	X	Z	Z
RECEIVER SECTION				
\overline{RE}	DE	A-B		RO
L	L	$\geq +0.2V$		H
L	L	$\leq -0.2V$		L
H	X	X		Z
L	L	OPEN *		H

Note: * = Non Terminated, Open Input only

X = Irrelevant

Z = TRI-STATE

H = High level

L = Low level

Pin Descriptions

Pin #	I/O	Name	Function
1	O	RO	Receiver Output: If $A > B$ by 200 mV, RO will be high; If $A < B$ by 200mV, RO will be low. RO will be high also if the inputs (A and B) are open (non-terminated)
2	I	\overline{RE}	Receiver Output Enable: RO is enabled when \overline{RE} is low; RO is in TRI-STATE when \overline{RE} is high
3	I	DE	Driver Output Enable: The driver outputs (A and B) are enabled when DE is high; they are in TRI-STATE when DE is low. Pins A and B also function as the receiver input pins (see below)
4	I	DI	Driver Input: A low on DI forces A low and B high while a high on DI forces A high and B low when the driver is enabled
5	N/A	GND	Ground
6	I/O	A	Non-inverting Driver Output and Receiver Input pin. Driver Output levels conform to RS-485 signaling levels
7	I/O	B	Inverting Driver Output and Receiver Input pin. Driver Output levels conform to RS-485 signaling levels
8	N/A	V_{CC}	Power Supply: $4.75V \leq V_{CC} \leq 5.25V$

Ordering Information

Package	Part Number	Package Marking	Transport Media	NSC Drawing
8-Pin SOIC	LMS1487CM	LMS1487CM	95 Units/Rail	M08A
	LMS1487CMX		2.5k Units Tape and Reel	
	LMS1487IM	LMS1487IM	95 Units/Rail	
	LMS1487IMX		2.5k Units Tape and Reel	
8-Pin DIP	LMS1487CNA	LMS1487CNA	40 Units/Rail	N08E
	LMS1487INA	LMS1487INA	40 Units/Rail	

Absolute Maximum Ratings (Note 1)

If Military/Aerospace specified devices are required, please contact the National Semiconductor Sales Office/Distributors for availability and specifications.

Supply Voltage, V_{CC} (Note 2)	7V
Input Voltage, V_{IN} (DI, DE, or \overline{RE})	-0.3V to $V_{CC} + 0.3V$
Voltage Range at Any Bus Terminal (AB)	-7V to 12V
Receiver Outputs	-0.3V to $V_{CC} + 0.3V$
Package Thermal Impedance, θ_{JA}	
SOIC	125°C/W
DIP	88°C/W
Junction Temperature (Note 3)	150°C
Operating Free-Air Temperature Range, T_A	
Commercial	0°C to 70°C
Industrial	-40°C to 85°C
Storage Temperature Range	-65°C to 150°C
Soldering Information	
Infrared or Convection (20 sec.)	235°C
Lead Temperature	260°C

ESD Rating (Note 4)

7kV

Operating Ratings

	Min	Nom	Max	
Supply Voltage, V_{CC}	4.75	5.0	5.25	V
Voltage at any Bus Terminal (Separately or Common Mode)	-7		12	V
V_{IN} or V_{IC}				
High-Level Input Voltage, V_{IH} (Note 5)	2			V
Low-Level Input Voltage, V_{IL} (Note 5)			0.8	V
Differential Input Voltage, V_{ID} (Note 6)			±12	V
High-Level Output				
Driver, I_{OH}			-150	mA
Receiver, I_{OH}			-42	mA
Low-Level Output				
Driver, I_{OL}			80	mA
Receiver, I_{OL}			26	mA

Electrical Characteristics

Over recommended ranges of supply voltage and operating free-air temperature (unless otherwise noted)

Symbol	Parameter	Conditions	Min	Typ	Max	Units
Driver Section						
$ V_{OD1} $	Differential Output Voltage	$R = \infty$ (Figure 1)			5.25	V
$ V_{OD2} $	Differential Output Voltage	$R = 50\Omega$ (Figure 1), RS-422	2.0			V
		$R = 27\Omega$ (Figure 1), RS-485	1.5		5.0	
ΔV_{OD}	Change in Magnitude of Driver Differential Output Voltage for Complementary Output States	$R = 27\Omega$ or 50Ω (Figure 1), (Note 7)			0.2	V
V_{OC}	Common-Mode Output Voltage	$R = 27\Omega$ or 50Ω (Figure 1)			3.0	V
ΔV_{OC}	Change in Magnitude of Driver Common-Mode Output Voltage for Complementary Output States	$R = 27\Omega$ or 50Ω (Figure 1), (Note 7)			0.2	V
V_{IH}	CMOS Inout Logic Threshold High	DE, DI, \overline{RE}	2.0			V
V_{IL}	CMOS Input Logic Threshold Low	DE, DI, \overline{RE}			0.8	V
I_{IN1}	Logic Input Current	DE, DI, \overline{RE}			±2	µA
Receiver Section						
I_{IN2}	Input Current (A, B)	DE = 0V, $V_{CC} = 0V$ or 5.25V			0.25	mA
		$V_{IN} = 12V$				
		$V_{IN} = -7V$			-0.2	
V_{TH}	Differential Input Threshold Voltage	$-7V \leq V_{CM} \leq +12V$	-0.2		+0.2	V
ΔV_{TH}	Input Hysteresis Voltage ($V_{TH+} - V_{TH-}$)	$V_{CM} = 0$		95		mV

Electrical Characteristics (Continued)

Over recommended ranges of supply voltage and operating free-air temperature (unless otherwise noted)

Symbol	Parameter	Conditions	Min	Typ	Max	Units
V_{OH}	CMOS High-level Output Voltage	$I_{OH} = -4\text{mA}$, $V_{ID} = 200\text{mV}$	3.5			V
V_{OL}	CMOS Low-level	$I_{OL} = 4\text{mA}$, $V_{ID} = -200\text{mV}$			0.40	V
I_{OZR}	Tristate Output Leakage Current	$0.4\text{V} \leq V_O \leq +2.4\text{V}$			± 1	μA
R_{IN}	Input Resistance	$-7\text{V} \leq V_{CM} \leq +12\text{V}$	48			$\text{k}\Omega$
Power Supply Current						
I_{CC}	Supply Current	$DE = V_{CC}$, $\overline{RE} = \text{GND}$ or V_{CC}		320	500	μA
		$DE = 0\text{V}$, $\overline{RE} = \text{GND}$ or V_{CC}		315	400	
I_{OSD1}	Driver Short-circuit Output Current	$V_O = \text{high}$, $-7\text{V} \leq V_{CM} \leq +12\text{V}$ (Note 8)	35		250	mA
I_{OSD2}	Driver Short-circuit Output Current	$V_O = \text{low}$, $-7\text{V} \leq V_{CM} \leq +12\text{V}$ (Note 8)	35		250	mA
I_{OSR}	Receiver Short-circuit Output Current	$0\text{V} \leq V_O \leq V_{CC}$	7		95	mA
Switching Characteristics						
Driver						
T_{PLH} , T_{PHL}	Propagation Delay Input to Output	$R_L = 54\Omega$, $C_L = 100\text{pF}$ (Figure 3, Figure 7)	10	35	60	nS
T_{SKEW}	Driver Output Skew	$R_L = 54\Omega$, $C_L = 100\text{pF}$ (Figure 3, Figure 7)		5	10	nS
T_R , T_F	Driver Rise and Fall Time	$R_L = 54\Omega$, $C_L = 100\text{pF}$ (Figure 3, Figure 7)	3	8	40	nS
T_{ZH} , T_{ZL}	Driver Enable to Output Valid Time	$C_L = 100\text{pF}$, $R_L = 500\Omega$ (Figure 4, Figure 8)		25	70	nS
T_{HZ} , T_{LZ}	Driver Output Disable Time	$C_L = 15\text{pF}$, $R_L = 500\Omega$ (Figure 4, Figure 8)		30	70	nS
Receiver						
T_{PLH} , T_{PHL}	Propagation Delay Input to Output	$R_L = 54\Omega$, $C_L = 100\text{pF}$ (Figure 5, Figure 7)	20	50	200	nS
T_{SKEW}	Receiver Output Skew	$R_L = 54\Omega$, $C_L = 100\text{pF}$ (Figure 5, Figure 7)		5		nS
T_{ZH} , T_{ZL}	Receiver Enable Time	$C_L = 15\text{pF}$, $R_L = 1\text{k}\Omega$ (Figure 6, Figure 10)		20	50	nS
	Receiver Disable Time			20	50	nS
F_{MAX}	Maximum Data Rate		2.5			Mbps

Note 1: Absolute Maximum Ratings indicate limits beyond which damage to the device may occur. Operating Ratings indicate conditions for which the device is intended to be functional, but specific performance is not guaranteed. For guaranteed specifications and the test conditions, see the Electrical Characteristics

Note 2: All voltage values, except differential I/O bus voltage, are with respect to network ground terminal.

Note 3: The maximum power dissipation is a function of $T_{J(\text{MAX})}$, θ_{JA} , and T_A . The maximum allowable power dissipation at any ambient temperature is $P_D = (T_{J(\text{MAX})} - T_A)/\theta_{JA}$. All numbers apply for packages soldered directly into a PC board.

Note 4: ESD rating based upon human body model, 100pF discharged through 1.5k Ω .

Note 5: Voltage limits apply to DI, DE, \overline{RE} pins.

Note 6: Differential input/output bus voltage is measured at the non-inverting terminal A with respect to the inverting terminal B.

Note 7: $|\Delta V_{OD}|$ and $|\Delta V_{OC}|$ are changes in magnitude of V_{OD} and V_{OC} , respectively when the input changes from high to low levels.

Note 8: Peak current

Typical Performance Characteristics

Output Current vs. Receiver Output Low Voltage

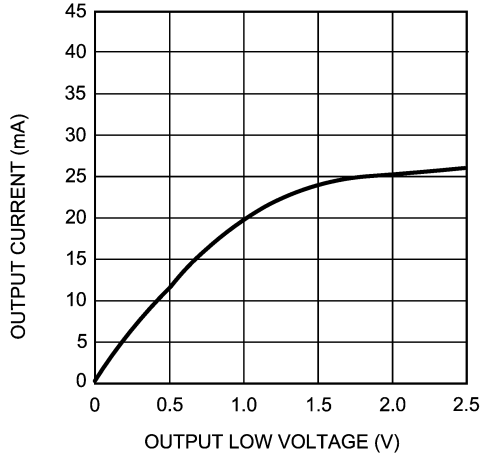

20053013

Output Current vs. Receiver Output High Voltage

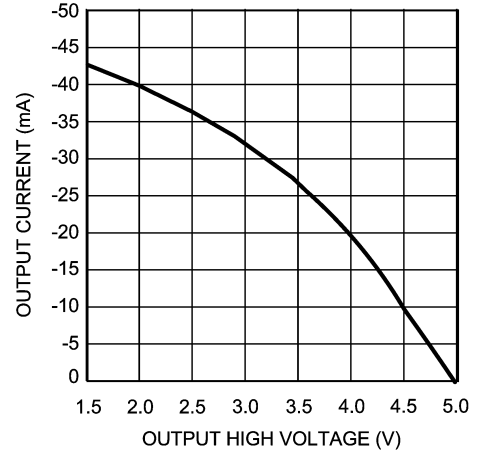

20053014

Receiver Output High Voltage vs. Temperature

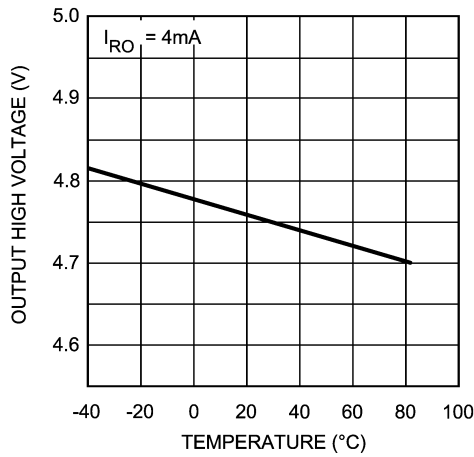

20053015

Receiver Output Low-Voltage vs. Temperature

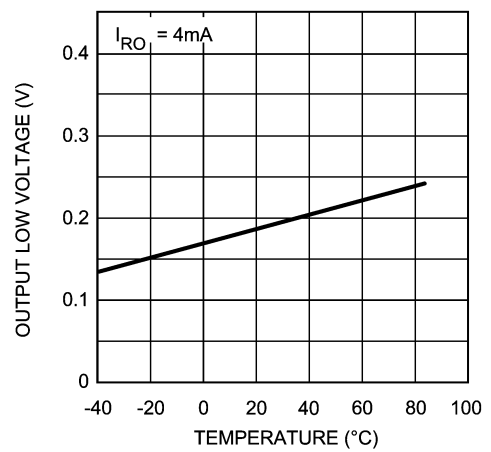

20053016

Driver Output Current vs. Differential Output Voltage

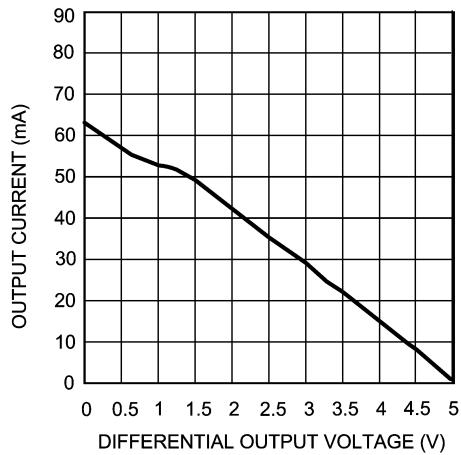

20053017

Driver Differential Output Voltage vs. Temperature

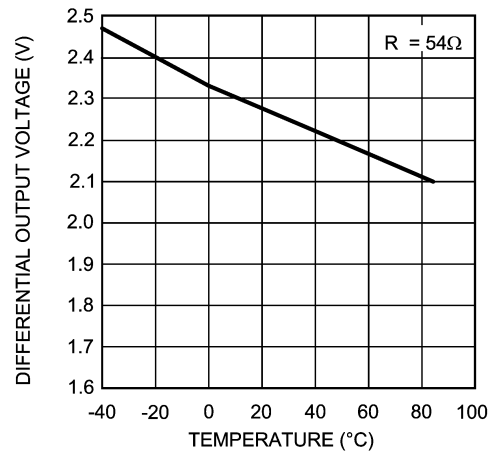

20053018

Typical Performance Characteristics (Continued)

Output Current vs. Driver Output Low Voltage

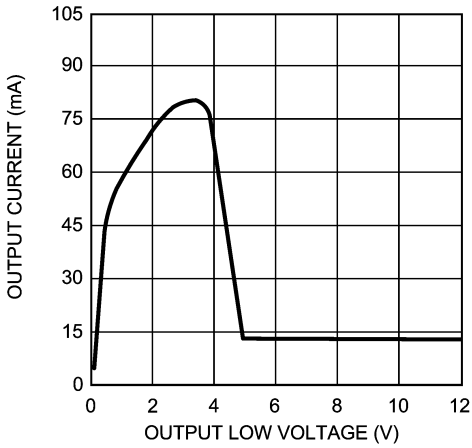

20053019

Output Current vs. Driver Output High Voltage

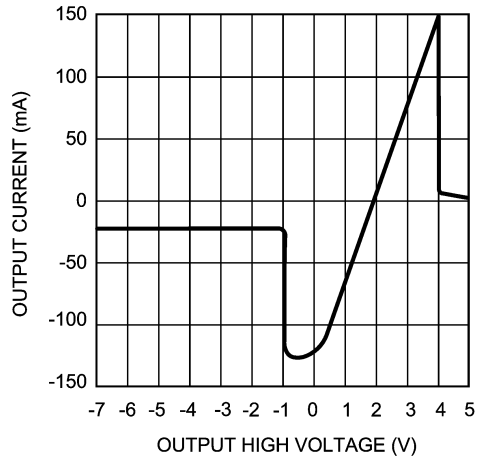

20053020

Supply Current vs. Temperature

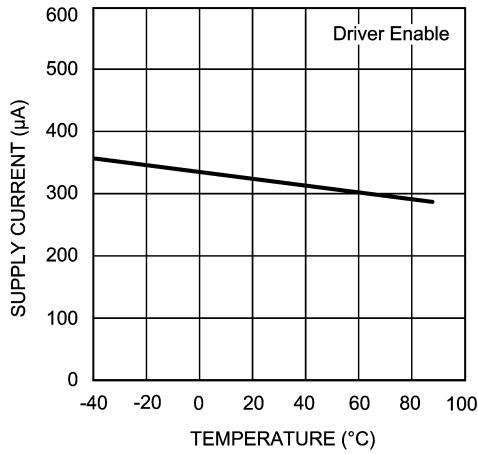

20053021

Parameter Measuring Information

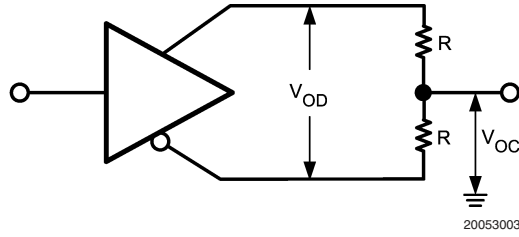

FIGURE 1. Test Circuit for V_{OD} and V_{OC}

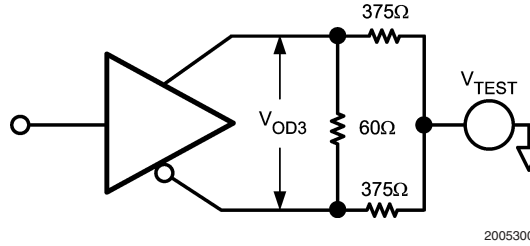

FIGURE 2. Test Circuit for V_{OD3}

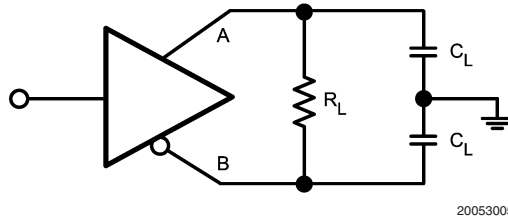

FIGURE 3. Test Circuit for Driver Propagation Delay

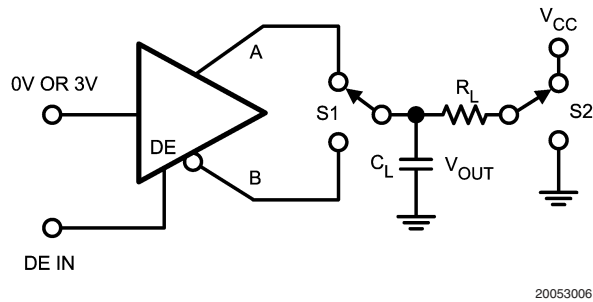
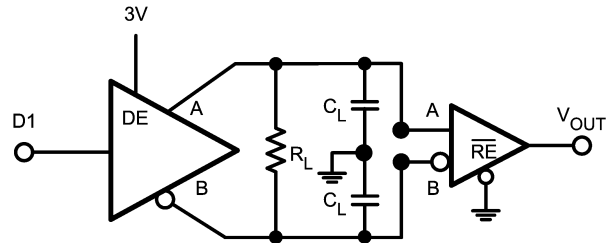

FIGURE 4. Test Circuit for Driver Enable / Disable

Parameter Measuring Information (Continued)



20053007

FIGURE 5. Test Circuit for Receiver Propagation Delay

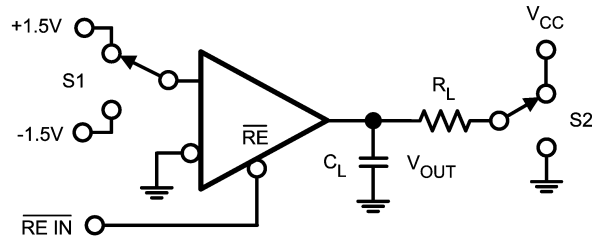

20053008

FIGURE 6. Test Circuit for Receiver Enable / Disable

Switching Characteristics

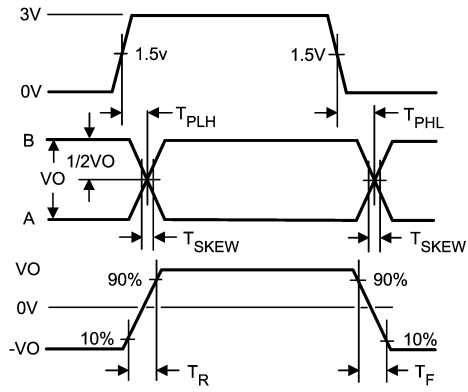

20053009

FIGURE 7. Driver Propagation Delay, Rise / Fall Time

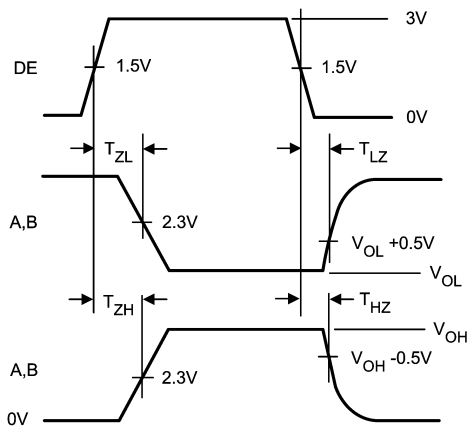

20053010

FIGURE 8. Driver Enable / Disable Time

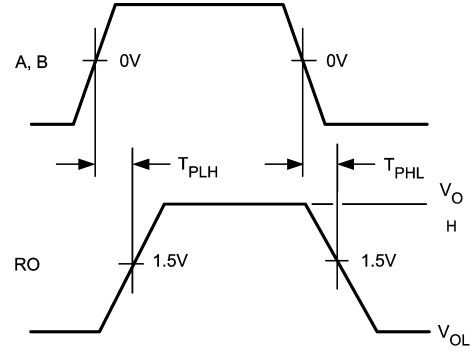

20053011

FIGURE 9. Receiver Propagation Delay

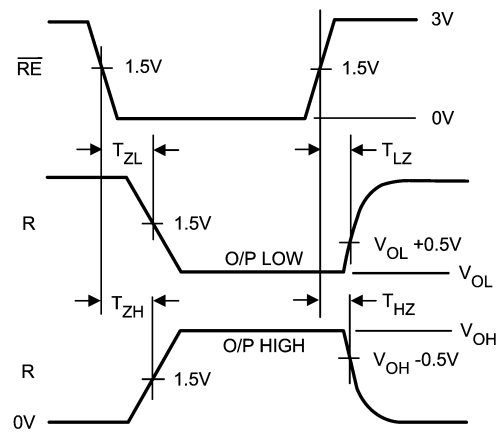

20053012

FIGURE 10. Receiver Enable / Disable Time

Application Information

POWER LINE NOISE FILTERING

A factor to consider in designing power and ground is noise filtering. A noise filtering circuit is designed to prevent noise generated by the integrated circuit (IC) as well as noise entering the IC from other devices. A common filtering method is to place by-pass capacitors (C_{bp}) between the power and ground lines.

Placing a by-pass capacitor (C_{bp}) with the correct value at the proper location solves many power supply noise problems. Choosing the correct capacitor value is based upon the desired noise filtering range. Since capacitors are not

ideal, they may act more like inductors or resistors over a specific frequency range. Thus, many times two by-pass capacitors may be used to filter a wider bandwidth of noise. It is highly recommended to place a larger capacitor, such as $10\mu\text{F}$, between the power supply pin and ground to filter out low frequencies and a $0.1\mu\text{F}$ to filter out high frequencies.

By-pass capacitors must be mounted as close as possible to the IC to be effective. Long leads produce higher impedance at higher frequencies due to stray inductance. Thus, this will reduce the by-pass capacitor's effectiveness. Surface mounted chip capacitors are the best solution because they have lower inductance.

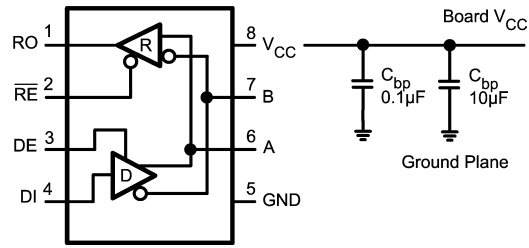

20053022

FIGURE 11. Placement of by-pass Capacitors, C_{bp}

Physical Dimensions inches (millimeters) unless otherwise noted

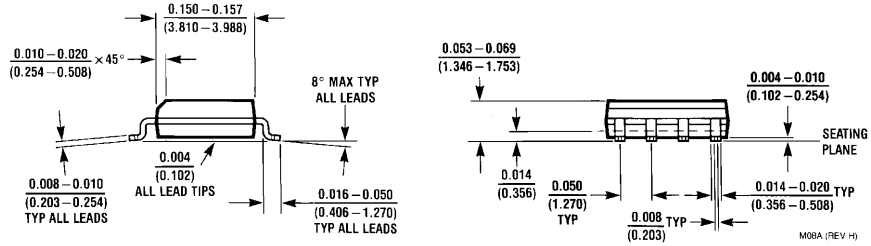
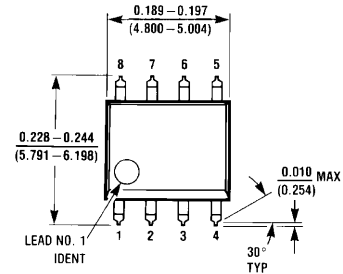

8-Pin SOIC
NS Package Number M08A

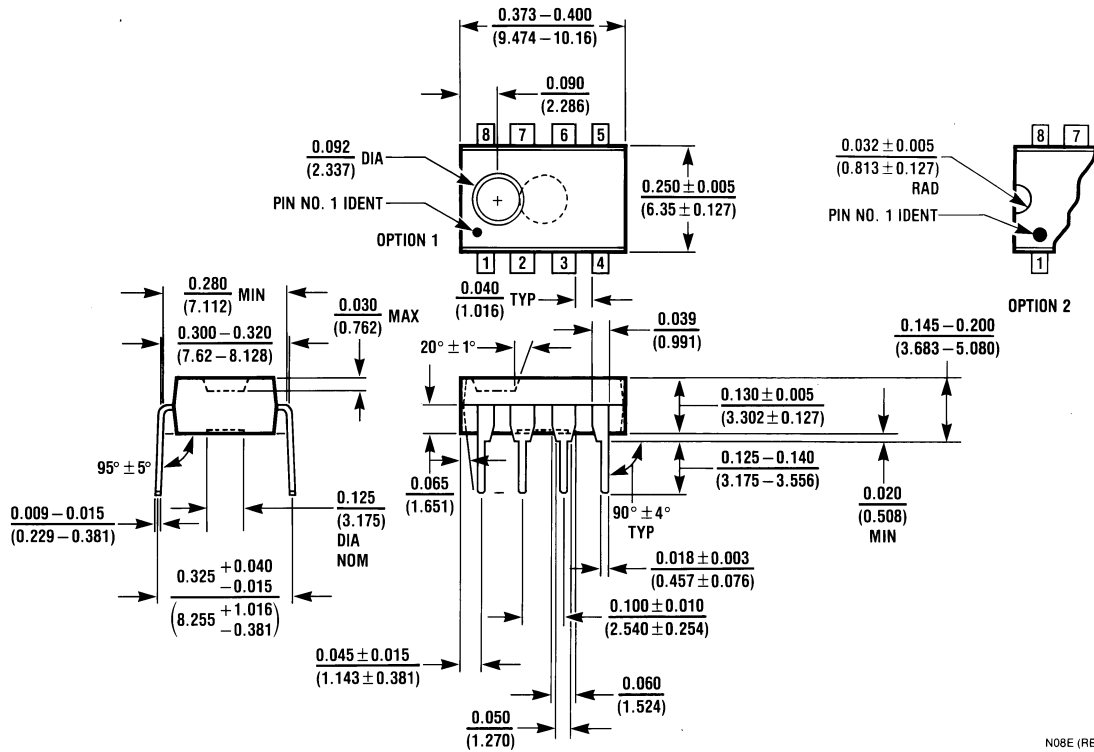

8-Pin DIP
NS Package Number N08E

Notes

LIFE SUPPORT POLICY

NATIONAL'S PRODUCTS ARE NOT AUTHORIZED FOR USE AS CRITICAL COMPONENTS IN LIFE SUPPORT DEVICES OR SYSTEMS WITHOUT THE EXPRESS WRITTEN APPROVAL OF THE PRESIDENT AND GENERAL COUNSEL OF NATIONAL SEMICONDUCTOR CORPORATION. As used herein:

1. Life support devices or systems are devices or systems which, (a) are intended for surgical implant into the body, or (b) support or sustain life, and whose failure to perform when properly used in accordance with instructions for use provided in the labeling, can be reasonably expected to result in a significant injury to the user.
2. A critical component is any component of a life support device or system whose failure to perform can be reasonably expected to cause the failure of the life support device or system, or to affect its safety or effectiveness.



National Semiconductor
Americas Customer
Support Center
Email: new.feedback@nsc.com
Tel: 1-800-272-9959

www.national.com

National Semiconductor
Europe Customer Support Center
Fax: +49 (0) 180-530 85 86
Email: europe.support@nsc.com
Deutsch Tel: +49 (0) 69 9508 6208
English Tel: +44 (0) 870 24 0 2171
Français Tel: +33 (0) 1 41 91 8790

National Semiconductor
Asia Pacific Customer
Support Center
Email: ap.support@nsc.com

National Semiconductor
Japan Customer Support Center
Fax: 81-3-5639-7507
Email: jpn.feedback@nsc.com
Tel: 81-3-5639-7560